

ZHEJIANG YONGTAILONG ELECTRONIC CO., LTD

ELECTRIC DOUBLE LAYER CAPACITORS

PRODUCT SPECIFICATION

規格書

CUSTOMER :

(客戶) :

DATE :

(日期) : 2018-06-09

CATEGORY (品名) : ELECTRIC DOUBLE LAYER CAPACITORS

DESCRIPTION (型号) : DRL 2.7V10 F (ϕ 12.5x20)

VERSION (版本) : 01

Customer P/N : /

SUPPLIER : /

SUPPLIER

PREPARED
(拟定)

CHECKED
(审核)

杜焕

刘渭清

CUSTOMER

APPROVAL
(批准)

SIGNATURE
(签名)

	ELECTRIC DOUBLE LAYER CAPACITORS SPECIFICATION DRL SERIES	
--	--	--

CONTENTS

	Sheet
1. Application	3
2. Part Number System	3
3. Characteristics	4~10
3.1 Rated voltage & Surge voltage	
3.2 Capacitance (Tolerance)	
3.3 ESR	
3.4 Leakage current	
3.5 Temperature characteristic	
3.6 Load life test	
3.7 Damp heat test	
3.8 Lead strength	
3.9 Resistance to vibration	
3.10 Solderability	
3.11 Resistance to soldering heat	
4. Product Dimensions	11
5. Notice item	12

Issued-date: 2018-06-09	Name	Specification Sheet – DRL		
Version	01		Page	2
STANDARD MANUAL				

**ELECTRIC DOUBLE LAYER
CAPACITORS
SPECIFICATION
DRL SERIES**

1. Application

The specification applies to electric double layer capacitors used in electronic equipment.

2. Part Number System

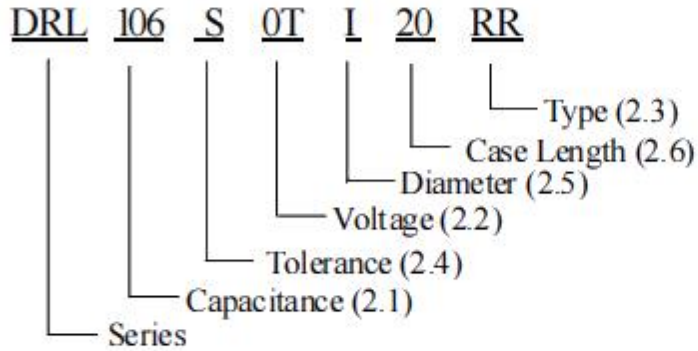

2.1 Capacitance code

Code	106
Capacitance (F)	10

2.2 Rated voltage code

Code	0T
Voltage (W.V.)	2.7

2.3 Type

Code	RR
Type	Bulk

2.4 Capacitance tolerance

“S” stands for -20% ~ +50%

2.5 Diameter

Code	I
Diameter	12.5

2.6 Case length

20=20mm

Issued-date: 2018-06-09	Name	Specification Sheet – DRL		
Version	01	Page	3	
STANDARD MANUAL				

	ELECTRIC DOUBLE LAYER CAPACITORS SPECIFICATION DRL SERIES	

3. Characteristics

Standard atmospheric conditions

Unless otherwise specified, the standard range of atmospheric conditions for making measurements and tests is as follows:

Ambient temperature: 15°C to 35°C

Relative humidity : 25% to 75%

Air Pressure : 86kPa to 106kPa

If there is any doubt about the results, measurement shall be made within the following conditions:

Ambient temperature: 20°C ± 2°C

Relative humidity : 60% to 70%

Air Pressure : 86kPa to 106kPa

Operating temperature range

The ambient temperature range at which the capacitor can be operated continuously at rated voltage is -40°C to 70°C.

Issued-date: 2018-06-09	Name	Specification Sheet – DRL	
Version	01	Page	4
STANDARD MANUAL			

**ELECTRIC DOUBLE LAYER
CAPACITORS
SPECIFICATION
DRL SERIES**

ITEM		PERFORMANCE				
3.1	Rated voltage (WV) Surge voltage (SV)	<table border="1"> <tr> <td>WV (V.DC)</td> <td>2.7</td> </tr> <tr> <td>SV (V.DC)</td> <td>2.8</td> </tr> </table>	WV (V.DC)	2.7	SV (V.DC)	2.8
WV (V.DC)	2.7					
SV (V.DC)	2.8					
3.2	Nominal capacitance (Tolerance)	<p><Condition> Constant current discharge method: Measuring circuit:</p> <p>Key (A) d.c. ammeter (V) d.c. voltmeter S changeover switch Cx capacitor under test</p> <p style="text-align: center;">Figure 1- Circuit for constant current discharge method</p> <p>Measuring method</p> <ol style="list-style-type: none"> Set the d.c.voltage at the rated voltage (U_R) Set the constant current value of the constant current discharger to the discharge current specified in Table 1. Turn the switch S to the d.c.power supply ,apply voltage and charge for 30 min after the constant current / constant voltage power supply has achieved the rated voltage. After a charge for 30 min has finished ,change over the switch S to the constant current discharger ,and discharge with a constant current. Measure the time t_1 and t_2 where the voltage between capacitor terminals at the time of discharge reduces from U_1 to U_2 as shown in Figure 2 ,and calculate the capacitance value by the following formula: 				

Issued-date: 2018-06-09

Name

Specification Sheet – DRL

Version

01

Page

5

STANDARD MANUAL

**ELECTRIC DOUBLE LAYER
CAPACITORS
SPECIFICATION
DRL SERIES**

<Condition>

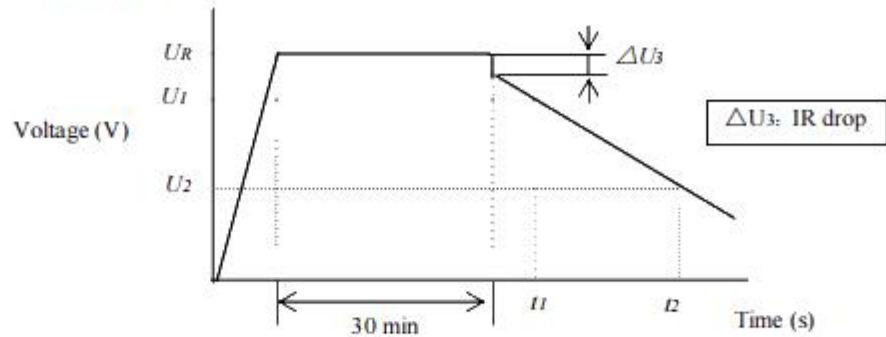

Figure 2- Voltage characteristic between capacitor terminals

$$C = \frac{I \times (t_2 - t_1)}{U_1 - U_2}$$

Where

- C is the capacitance(F);
- I is the discharge current (A);
- U_1 is the measurement starting voltage (V);
- U_2 is the measurement end voltage (V);
- t_1 is the time from discharge start to reach U_1 (s);
- t_2 is the time from discharge start to reach U_2 (s).

f) The discharge current I and the voltages U_1 and U_2 at the time of discharge voltage drop shall be as per Table 1 .The method classification shall be in accordance with the individual standards.

Table 1 – Discharge conditions

Charge time	30 min
I (mA)	$4 \times C U_R$
U_1	The value to be 80% of the charging voltage ($0.8 \times U_R$)
U_2	The value to be 40% of the charging voltage ($0.4 \times U_R$)
NOTE C_R is the rated capacitance in F(Farad),and U_R is the rated voltage in V (Volt)	

3.2 Nominal capacitance (Tolerance)

Issued-date: 2018-06-09

Name

Specification Sheet – DRL

Version

01

Page

6

STANDARD MANUAL

	ELECTRIC DOUBLE LAYER CAPACITORS SPECIFICATION DRL SERIES	
--	--	--

3.3	ESR	<p><Condition> Measuring frequency :1kHz Measuring temperature:20±2°C Measuring point : 2mm max from the surface of a sealing resin on the lead wire.</p> <p><Criteria> (20°C)Less than the initial limit ESR≤80mΩ</p>																								
3.4	Leakage current	<p><Condition> 1. Ambient temperature: 25°C ± 2°C. 2. The electrification time: 72H 3. Desistance value of protective resistor less than 1Ω .</p> <p><Criteria> Less than the initial limit(25°C ± 2°C): I≤0.025mA I is the Leakage current</p>																								
3.5	Temperature characteristic	<p><Condition></p> <table border="1" style="width: 100%; border-collapse: collapse;"> <thead> <tr> <th>STEP</th> <th>Temperature(°C)</th> <th>Item</th> <th>Characteristics</th> </tr> </thead> <tbody> <tr> <td style="text-align: center;">1</td> <td style="text-align: center;">20±2</td> <td>Capacitance、ESR</td> <td style="text-align: center;">-----</td> </tr> <tr> <td rowspan="2" style="text-align: center;">2</td> <td rowspan="2" style="text-align: center;">-40+3</td> <td style="text-align: center;">Δ C/C</td> <td style="text-align: center;">Within ±30% of initial capacitance</td> </tr> <tr> <td style="text-align: center;">ESR</td> <td style="text-align: center;">Less than or equal to 4 times of the value of item 3.3</td> </tr> <tr> <td style="text-align: center;">3</td> <td style="text-align: center;">Keep at 15 to 35°C for 15 minutes or more</td> <td style="text-align: center;">-----</td> <td style="text-align: center;">-----</td> </tr> <tr> <td rowspan="2" style="text-align: center;">4</td> <td rowspan="2" style="text-align: center;">70±2</td> <td style="text-align: center;">Δ C/C</td> <td style="text-align: center;">Within ±30% of initial capacitance</td> </tr> <tr> <td style="text-align: center;">ESR</td> <td style="text-align: center;">The limit specified in 3.3</td> </tr> </tbody> </table> <p>a. ESR -40°C/ ESR 20°C: ESR ratio at 1kHz; b. ΔC/C 20°C: Capacitance change ;</p>	STEP	Temperature(°C)	Item	Characteristics	1	20±2	Capacitance、ESR	-----	2	-40+3	Δ C/C	Within ±30% of initial capacitance	ESR	Less than or equal to 4 times of the value of item 3.3	3	Keep at 15 to 35°C for 15 minutes or more	-----	-----	4	70±2	Δ C/C	Within ±30% of initial capacitance	ESR	The limit specified in 3.3
STEP	Temperature(°C)	Item	Characteristics																							
1	20±2	Capacitance、ESR	-----																							
2	-40+3	Δ C/C	Within ±30% of initial capacitance																							
		ESR	Less than or equal to 4 times of the value of item 3.3																							
3	Keep at 15 to 35°C for 15 minutes or more	-----	-----																							
4	70±2	Δ C/C	Within ±30% of initial capacitance																							
		ESR	The limit specified in 3.3																							

**ELECTRIC DOUBLE LAYER
CAPACITORS
SPECIFICATION
DRL SERIES**

3.6	Load life test	<p><Condition> The Capacitor is stored at a temperature of 70±2 °C with rated voltage for 1000 +48/0 hours .The result should meet the following table:</p> <p><Criteria></p> <table border="1" style="width: 100%; border-collapse: collapse;"> <thead> <tr> <th style="width: 50%;">Item</th> <th style="width: 50%;">Performance</th> </tr> </thead> <tbody> <tr> <td>Capacitance Change</td> <td>Within ±30% of initial capacitance</td> </tr> <tr> <td>ESR</td> <td>Less than or equal to 4 times of the value of item 3.3</td> </tr> <tr> <td>Appearance</td> <td>No visible damage and no leakage of electrolyte</td> </tr> </tbody> </table>	Item	Performance	Capacitance Change	Within ±30% of initial capacitance	ESR	Less than or equal to 4 times of the value of item 3.3	Appearance	No visible damage and no leakage of electrolyte
Item	Performance									
Capacitance Change	Within ±30% of initial capacitance									
ESR	Less than or equal to 4 times of the value of item 3.3									
Appearance	No visible damage and no leakage of electrolyte									
3.7	Damp heat test	<p><Condition> Humidity Test: The capacitor shall be exposed for 240±48 hours in an atmosphere of 90~95%RH at 40±2°C, the characteristic change shall meet the following requirement.</p> <p><Criteria></p> <table border="1" style="width: 100%; border-collapse: collapse;"> <thead> <tr> <th style="width: 50%;">Item</th> <th style="width: 50%;">Performance</th> </tr> </thead> <tbody> <tr> <td>Capacitance Change</td> <td>Within ±30% of initial capacitance</td> </tr> <tr> <td>ESR</td> <td>Less than or equal to 4 times of the value of item 3.3</td> </tr> <tr> <td>Appearance</td> <td>No visible damage and no leakage of electrolyte</td> </tr> </tbody> </table>	Item	Performance	Capacitance Change	Within ±30% of initial capacitance	ESR	Less than or equal to 4 times of the value of item 3.3	Appearance	No visible damage and no leakage of electrolyte
Item	Performance									
Capacitance Change	Within ±30% of initial capacitance									
ESR	Less than or equal to 4 times of the value of item 3.3									
Appearance	No visible damage and no leakage of electrolyte									

Issued-date: 2018-06-09	Name	Specification Sheet – DRL		
Version	01	Page	8	
STANDARD MANUAL				

**ELECTRIC DOUBLE LAYER
CAPACITORS
SPECIFICATION
DRL SERIES**

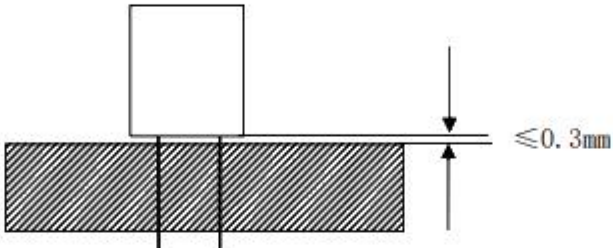
3.8	Lead strength	<p>a) Lead pull strength A static load force shall be applied to the terminal in the axial direction and acting in a direction away from the body for 10±1 s.</p> <table border="1" style="margin-left: auto; margin-right: auto;"> <tr> <th style="text-align: center;">Lead wire diameter (mm)</th> <th style="text-align: center;">Load force (N)</th> </tr> <tr> <td style="text-align: center;">$0.5 < d \leq 0.8$</td> <td style="text-align: center;">10</td> </tr> </table> <p>b) Lead bending When the capacitor is placed in a vertical position and the weight specified in the table above is applied to one lead and then the capacitor is slowly rotated 90° to a horizontal position and then returned to a vertical position thus completing bends for 2~3seconds. The additional bends are made in the opposite direction</p> <table border="1" style="margin-left: auto; margin-right: auto;"> <tr> <th style="text-align: center;">Lead wire diameter (mm)</th> <th style="text-align: center;">Load force (N)</th> </tr> <tr> <td style="text-align: center;">$0.5 < d \leq 0.8$</td> <td style="text-align: center;">5</td> </tr> </table> <p>Performance: The characteristic shall meet the following value after a) or b) test.</p> <table border="1" style="margin-left: auto; margin-right: auto;"> <tr> <th style="text-align: center;">Item</th> <th style="text-align: center;">Performance</th> </tr> <tr> <td style="text-align: center;">Capacitance Change</td> <td style="text-align: center;">Within ±30% of initial capacitance</td> </tr> <tr> <td style="text-align: center;">Appearance</td> <td style="text-align: center;">No visible damage Legible marking and no leakage of electrolyte</td> </tr> </table>	Lead wire diameter (mm)	Load force (N)	$0.5 < d \leq 0.8$	10	Lead wire diameter (mm)	Load force (N)	$0.5 < d \leq 0.8$	5	Item	Performance	Capacitance Change	Within ±30% of initial capacitance	Appearance	No visible damage Legible marking and no leakage of electrolyte
Lead wire diameter (mm)	Load force (N)															
$0.5 < d \leq 0.8$	10															
Lead wire diameter (mm)	Load force (N)															
$0.5 < d \leq 0.8$	5															
Item	Performance															
Capacitance Change	Within ±30% of initial capacitance															
Appearance	No visible damage Legible marking and no leakage of electrolyte															
3.9	Resistance to vibration	<p>Frequency: 10 to 55 Hz (1minute interval / 10 → 55 → 10Hz) Amplitude: 0.75mm(Total excursion 1.5mm) Direction :X、 Y、 Z (3 axes) Duration: 2hours/ axial (Total 6 hours) The capacitors are supported as the following Fig2</p> <div style="text-align: center;">  </div> <p style="text-align: center;">Fig2</p> <p>Performance: Capacitance value shall not show drastic change compared to the initial capacitance when the value is measured within 30 minutes. Prior to the completion of exam, Capacitance difference shall be within ±10% compared to the initial value the exam.</p>														

Issued-date: 2018-06-09	Name	Specification Sheet – DRL		
Version	01	Page	9	
STANDARD MANUAL				

**ELECTRIC DOUBLE LAYER
CAPACITORS
SPECIFICATION
DRL SERIES**

3.10	Solderability	<p>The capacitor shall be tested under the following conditions: Solder : Sn-3Ag-0.5Cu Soldering temperature: 245±3°C Immersing time : 2.0±0.5s Immersing depth : 1.5~ 2.0mm from the root. Flux : Approx .25% rosin</p> <p>Performance: At least 75% of the dipped portion of the terminal shall be covered with new solder.</p>						
3.11	Resistance to soldering heat	<p>A) Solder bath method Lead terminals of a capacitor are placed on the heat isolation board with thickness of 1.6±0.5mm. It will dip into the flux of isopropylalcohol solution of colophony. Then it will be immersed at the surface of the solder with the following condition: Solder : Sn-3Ag-0.5Cu Soldering temperature : 260 ±5°C Immersing time : 5±0.5s Heat protector: τ=1.6mm glass –epoxy board</p> <p>B) Soldering iron method Bit temperature : 350 ±10°C Application time : 3.5 ±0.5 s Heat protector: τ=1.6mm glass –epoxy board</p> <p>For both methods, after the capacitor at thermal stability, the following items shall be measured:</p> <table border="1" style="width: 100%; border-collapse: collapse;"> <thead> <tr> <th style="text-align: left;">Item</th> <th style="text-align: left;">Performance</th> </tr> </thead> <tbody> <tr> <td>Capacitance Change</td> <td>Within ±10% of initial capacitance</td> </tr> <tr> <td>Appearance</td> <td>No visible damage legible marking and no leakage of electrolyte</td> </tr> </tbody> </table>	Item	Performance	Capacitance Change	Within ±10% of initial capacitance	Appearance	No visible damage legible marking and no leakage of electrolyte
Item	Performance							
Capacitance Change	Within ±10% of initial capacitance							
Appearance	No visible damage legible marking and no leakage of electrolyte							

Issued-date: 2018-06-09	Name	Specification Sheet – DRL		
Version	01	Page	10	
STANDARD MANUAL				

**ELECTRIC DOUBLE LAYER
CAPACITORS
SPECIFICATION
DRL SERIES**

4. Product Dimensions

Unit: mm

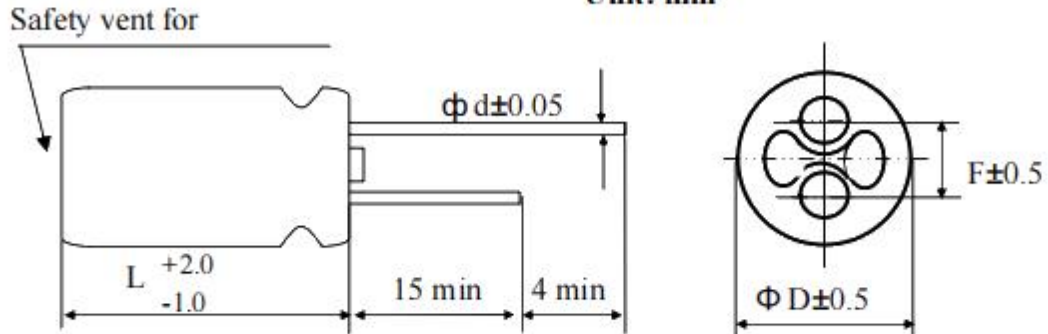

ϕD	12.5
L	20
F	5.0
ϕd	0.6

Issued-date: 2018-06-09

Name

Specification Sheet – DRL

Version

01

Page

11

STANDARD MANUAL

	ELECTRIC DOUBLE LAYER CAPACITORS SPECIFICATION DRL SERIES	

5 . Notice item

- (1) The capacitor has fixed polarity.
- (2) The capacitor should be used under rated voltage.
- (3) The capacitor should not be used in the charge and discharge circuit with high frequency.
- (4) The ambient temperature affects the super capacitor life.
- (5) Voltage reduction $\Delta V=IR$ will happen at the moment of discharge.
- (6) The capacitor cannot be stored on the place with humidity over 85%RH or place with toxic gas.
- (7) The capacitor should stored in the environment within -30°C~50°C temperature and less than 60% relative humidity.
- (8) If the capacitor is applied on the double-side PCB, the connection should not be around the place on which the super capacitor can contact.
- (9) Don't twist capacitor or make it slanting after installing.
- (10) Need avoid over heat on the capacitor during soldering (The temperature should be 260°C with the time less than 5s during soldering on 1.6mm printed PCB.)
- (11) There is voltage balance problem between each capacitor unit during series connection between super capacitor.

Issued-date: 2018-06-09	Name	Specification Sheet – DRL	
Version	01	Page	12
STANDARD MANUAL			

寿命 Lifespan

贮存寿命 Shelf Life	+60°C下无负荷贮存1,000小时后电容器符合规定的限值 After 1,000 hours storage at +60°C without load, the capacitor shall meet the specified limits for endurance.	
耐用性 Endurance	+60°C下采用额定电压1,000小时后电容器符合以下限定值 After 1,000 hours application of rated voltage at +60°C, the capacitor shall meet the following limits.	
	容量变化 Capacitance Change	初始测试值的±30% ±30% of initial measured value
	内阻 Internal Resistance	≤初始值的2倍 ≤2 times of initial specified value
循环次数 Cycles		
循环次数 Cycles	在+25°C下·用恒定电流使电容器在规定电压和半额定电压间循环充放电(500,000次) Capacitors cycles between specified voltage and half rated voltage under constant current at +25°C (500,000 cycles)	
	容量变化 Capacitance Change	初始测试值的±30% ±30% of initial measured value
	内阻 Internal Resistance	≤初始值的2倍 ≤2 times of initial specified value